

Institutional Animal Care & Use Program - UTEP	
Title: Isoflurane Waste Anesthetic Gas	
Policy#: 020	Date in Effect: 14 January 2015
Version #: A	Rev Date:
In Effect <input checked="" type="checkbox"/> Rescinded <input type="checkbox"/>	Date Rescinded:

A) RESPONSIBILITIES

It is the responsibility of all animal users who utilize gas anesthesia (e.g. isoflurane) in laboratory animals at UTEP to abide by this policy. It is the responsibility of the IACUC to review for approval, properly justified requests for an exception to this policy.

B) APPLICATION

- 1) Isoflurane is a commonly used anesthetic for many procedures in animal research facilities. This agent is delivered using either a precision vaporizer or the open-drop method, a technique often used for rodents in research. Personnel using either method for delivering isoflurane may be exposed to waste anesthetic gases (WAG). This policy is intended to provide isoflurane users with some basic guidelines for the proper use of isoflurane machines; describe its basic components; describe what is needed to perform an open-drop technique; and provide explanation of the most common practices that lead to human exposure.

C) REFERENCES

- 1) Taylor KT, Mook DM (2009). Isoflurane Waste Anesthetic Gas Concentration Associated with the Open-Drop Method. *Journal of the American Association for Laboratory Animal Science*, **48(1)**, 61–64.
- 2) [NIOSH Publication No. 2007- 151](#).
- 3) [International Chemical Safety](#) card (MSDS) for isoflurane.

D) DEFINITIONS

- 1) WAG – Waste Anesthetic Gases = small amounts of volatile anesthetic gases that leak from the anesthetic breathing circuit or open-drop jar into the air of the procedure room during delivery of anesthesia. Animals may also exhale these gases while recovering from anesthesia.

- 2) ppm – parts per million.
- 3) SDS –Safety Data Sheets.
- 4) Passive scavenging – relies on the positive pressure from the anesthetic gas delivery system and/or the exhalation effort of the animal to drive contaminated exhaled air through a specially designed activated charcoal filter (*e.g.*, F/Air, Enviro-Pure, etc.), which will adsorb and remove the waste anesthetic agent molecules before the air is discharged back into the room.
- 5) Active scavenging - involves using low-pressure high flow ventilation to create a suction that captures contaminated air and safely discharges it from the room and the building. The simplest form of active scavenging is to actually deliver the anesthetic to the animal while it is placed within a properly functioning exhausted hood, downdraft table or under a snorkel. Other systems may also be appropriate.
- 6) EH&S – Environmental Health & Safety Department

E) ANESTHESIA DELIVERY EQUIPMENT

- 1) Isoflurane vaporizer – precision delivery system designed for “out of circuit” use in continuous flow techniques of inhalation anesthesia (*Figure 1*). This is the preferred method for delivery of anesthetic gases.
 - a) Gas exposure risks.
 - (1) Exposure to gas from an improperly closed induction chamber.
 - (2) Leaks from connections between various system components.
 - (3) Improper fit of the mask or nose cone on the animal.
 - (4) Not using a scavenging system.
 - (5) Spilling liquid anesthetic agent while filling vaporizer reservoir or failing to adequately seal the reservoir or container afterward.
 - (6) Filling a vaporizer outside of the fume hood or away from the snorkel
 - (7) Working in a room or area with poor ventilation.
 - (8) Setting the vaporizer concentration and/or oxygen levels too high.
 - (9) Turning on the vaporizer before attaching a breathing system to an animal.
 - (10) Allowing the vaporizer to remain on after an animal is disconnected from the anesthesia system.

- (11) Allowing the charcoal filter to exceed its weight or time limit.
- (12) Excessive length of the scavenging tube from the animal to the passive or active scavenging system.

b) Practices to minimize or eliminate exposures:

- (1) Utilize a scavenging system (passive or active). Active scavenging is generally superior to passive systems.
- (2) Work in an exhausted hood or under a snorkel.
- (3) Work in a well-ventilated area (at least 10-15 air changes per hour).
- (4) Check anesthetic system connections for leaks.
- (5) Ensure the mask or nose cone fits snugly on the animal.
- (6) Distance yourself from the source of WAG (e.g. mask, induction chamber, animal) as much as possible to minimize exposure.
- (7) Turn off the vaporizer after use.
- (8) Ensure you are using the proper isoflurane and oxygen level concentration.
- (9) When possible, fill the vaporizer under an exhausted hood, downdraft table (exhausted out) or under a snorkel in a well-ventilated area.
- (10) Flush induction chambers for 10 seconds with oxygen (with active/passive scavenging in place) without isoflurane to allow removal of lingering waste gas.
- (11) Recap the isoflurane bottle and ensure the reservoir cap is adequately tightened immediately after filling the vaporizer reservoir.
- (12) Check and maintain the vaporizer's calibration. This includes having the unit certified annually. Consult Veterinary Services for further information.
- (13) Review the SDS for isoflurane.

2) Open-drop (jar) method under an exhausted hood, downdraft table or snorkel and examples of methods:

- a) If the open-drop method is proposed, this must be discussed with the Attending Veterinarian (AV) prior to approval. The AV will confirm that the

proposed setup and procedures for use with this method will be safe and effective for the animals under the intended circumstances.

- b) It is important to note that there is more risk involved with the open-drop method than with delivery via a precision vaporizer. Close monitoring of animals is paramount to avoid mortality and other complications.
- c) In addition, the open-drop method is intended for use only for induction prior to transfer of the animal to a precision vaporizer-maintained system, for very short procedures that do not require re-exposure to the drop-jar prior to completion of the procedure or for euthanasia purposes.
- d) Isoflurane is directly applied onto an absorbent material at the bottom of a jar equipped with a grate positioned above the absorbent material. Appropriate volumes of isoflurane per liter volume of the jar used and corresponding delivery percentages are noted in Table 1. The animal is then placed on the grate (located above the absorbent material to avoid direct contact of the animal with the anesthetic), and the lid is closed (*Figure 2A*). Alternatively, the anesthetic may be applied to absorbent material enclosed in a pathology cassette to avoid direct animal contact with the anesthetic (*Figure 2A*). Anesthesia gas fills the jar and the rodent is subsequently anesthetized.
- e) Isoflurane must be replenished over time to retain its potency for subsequent animals, if applicable. A general rule of thumb is to replenish after every three animals.
- f) Direct application of an isoflurane dilution onto an absorbent material within a syringe casing (*Figure 3*) or centrifuge tube of appropriate size to the animal.
 - (1) An animal's depth of anesthesia can be manipulated by moving the tube toward or away from the animal's nose as deemed appropriate by monitoring of physiologic parameters.
- g) Exposure can occur if:
 - (1) Not utilizing a scavenging system (e.g., an exhausted hood, downdraft table or under a snorkel).
 - (2) Working in an area or room with poor ventilation.
 - (3) Using an incorrect isoflurane concentration.

- (4) Spilling anesthetic while filling a reservoir or applying to absorbent material.
- (5) The jar lid is not properly closed.
- h) Practices to minimize or eliminate exposure:
 - (1) Only use the open-drop method in an exhausted hood, downdraft table or under a snorkel.
 - (2) Distance yourself from the source of WAG (e.g. mask, induction chamber, animal) as much as possible to minimize exposure.
 - (3) Make sure the jar lid is properly closed during induction and after use.
 - (4) Use the correct isoflurane concentration.
 - (5) Apply isoflurane to absorbent material under an exhausted hood, downdraft table or under a snorkel.
 - (6) Work in a well-ventilated room.
 - (7) Utilize an induction chamber designated for WAG scavenging (*Figure 4*)
 - (8) Recap the isoflurane bottle immediately after use.
 - (9) Review the SDS for isoflurane.

F) ENVIRONMENTAL AND WORK RISK ASSESSMENT

- 1) Personal monitoring can be conducted at the employee's breathing zone to determine WAG exposure for the employee. The monitoring is performed using a passive dosimeter, which collects gas on a media and is then analyzed by a laboratory. For more information contact EH&S.

Table 1

Volume of liquid agent/ 1000 ml chamber volume	Approximate concentration of isoflurane
0.05 ml	1%
0.1 ml	2%
0.2 ml	4%
0.3 ml	6%

Precision Delivery System

Figure 1

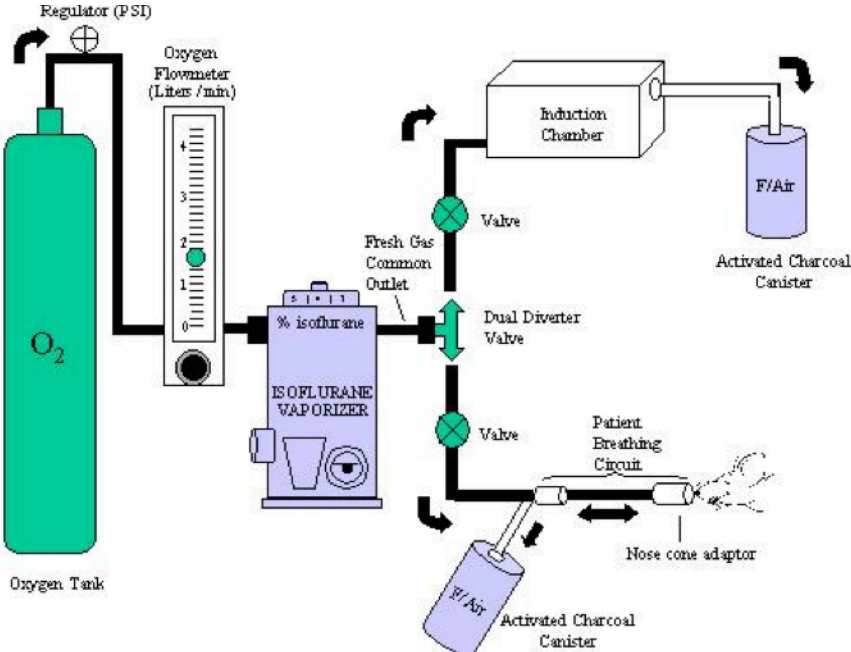

Figure 2A

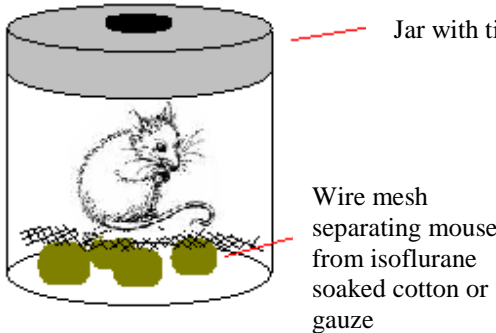

Figure 2B

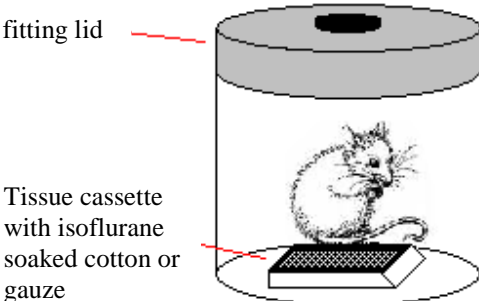

Figure 3

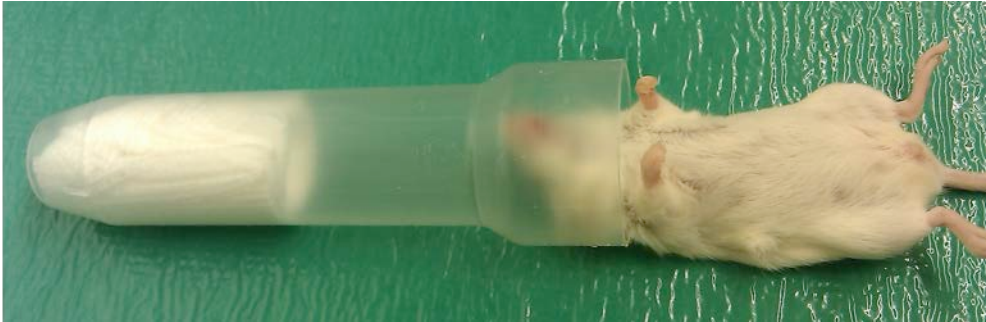

Figure 4

